

# AMTA-MAXI

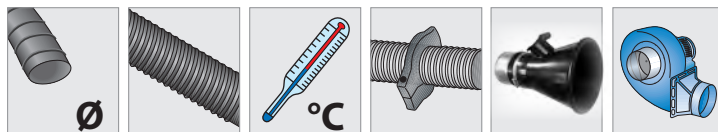

AMTA-MAXI-125/15-SB					
125 mm - 5"	15 mt - 50 ft	200° C - 392° F	-	-	1.5 HP - 1.1 Kw

AMTA-MAXI-125/ 17-SB					
125 mm - 5"	17 mt - 56 ft	200° C - 392° F	-	-	1.5 HP - 1.1 Kw

AMTA-MAXI-150/13-SB					
150 mm - 6"	13 mt - 43 ft	200° C - 392° F	-	-	1.5 HP - 1.1 Kw

AMTA-MAXI-200/10-SB					
200 mm - 8"	10 mt - 32 ft	200° C - 392° F	-	-	1.5 HP - 1.1 Kw



 Arrotolatore MAXI dotato di elettroaspiratore e di motorizzazione con telecomando per salita e discesa del tubo flessibile di aspirazione. Adatto all'installazione a soffitto e a parete. Completo di fincorsa elettrico di sicurezza e comando remoto di partenza/arresto del ventilatore.

 Motor driven MAXI hose reel with fan and remote control for the roll-up and down of the flexible hose for extraction. Suitable for wall or ceiling installation. Complete with electric safety stop and remote start/stop of the fan.

 Enrouleur MAXI avec montage et descente électrique du tuyau flexible pour l'aspiration des gaz d'échappement avec ventilateur et radio-commande. Installation au mur et au plafond. Equipé d'une fin de course de sécurité qui fonctionne pour le démarrage du ventilateur centralisé.

 Abgasschlauchaufroller MAXI für die Montage an der Wand oder Decke komplett mit Motorantrieb, Ventilator und Fernbedienungsfunktion Auf- Abrollen des Schlauches und Ein- Ausschalten des Ventilators. Komplett mit elektrischem Schlauchstopper.

 Enrollador MAXI, motorizado para el rebobinado automático de la manguera, y con aspirador. Mando a distancia para el control del rebobinado. Puede ser montado en techo o pared. Esta equipado con un 'fin de carrera' eléctrico, que también sirve para el encendido automático del aspirador.

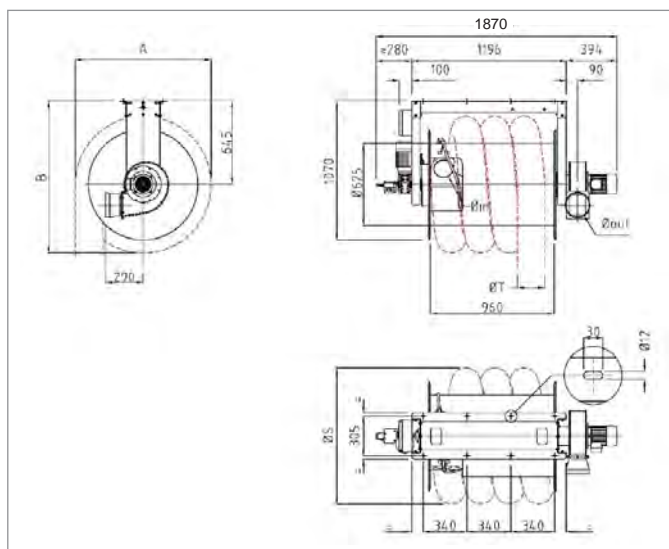

Mod	A (mm)	B (mm)	S Ø (mm)	T Ø EXT. (mm)	IN Ø (mm)	Fan	OUT Ø (mm)	Kw - Hp	Kw	Kg*	Kg tot**
AMTA-MAXI-125/15	907	1098.5	907	141	125	AL-150	180	1.1/1.5	0,25	101	124
AMTA-MAXI-125/15-D	907	1098.5	907	141	125	AL-150	160	1.1/1.5	0,25	101	124
AMTA-MAXI-125/17	907	1098.5	907	141	125	AL-150	180	1.1/1.5	0,25	101	126
AMTA-MAXI-125/17-D	907	1098.5	907	141	125	AL-150	160	1.1/1.5	0,25	101	126
AMTA-MAXI-150/13	957	1123.5	907	166	150	AL-150	180	1.1/1.5	0,25	101,5	125
AMTA-MAXI-150/13-D	957	1123.5	907	166	150	AL-150	160	1.1/1.5	0,25	101,5	125
AMTA-MAXI 200/10	1053	1171.5	1053	214	200	AL-150	180	1.1/1.5	0,25	102	127
AMTA-MAXI 200/10-D	1053	1171.5	1053	214	200	AL-150	160	1.1/1.5	0,25	102	127

\*Peso relativo all'arrotolatore SENZA tubazione flessibile e bocchetta - Weight of the retractor WITHOUT hose and nozzle - Poids de l'enrouleur SANS tuyau ni buse - Gewicht des Aufrollers OHNE Schlauch und Düse - El peso del retractor SIN manguera ni boquilla.

\*\*Peso relativo all'arrotolatore in versione "COMP" - Weight of the reel in "COMP" version - Poids de la bobine en version "COMP" - Gewicht der Spule in "COMP"-Version - El peso del carrete en la versión "COMP".